

SECTION 3 – CONTROL PANEL OPERATION

CAB CONTROL UNIT DESCRIPTION	U2086
CCU MOUNTING	U2103
DESCRIPTION OF MICROPROCESSOR PROGRAM ON TRUCK	U2049



CAB CONTROL UNIT DESCRIPTION

GENERAL DESCRIPTION

The Cab Control Unit (also referred to as CCU) is a group of parts consisting of the following: (See Figure 1)

1. An EPROM that stores the Weigh System program. The program monitors all the inputs, stores the data, controls the outputs, and communicates with a laptop computer and/or dispatch system.
2. Relays (5): These control the +24 Vdc power going to the CCU and the Dump Body.

This CCU is typically mounted behind the passenger seat.

NOTE: *On some trucks, these same parts may be mounted other places but they will normally be grouped together.*

OPERATION

While the truck's Master Switch is turned On, the CCU is operational and is collecting data. The initial setup of the unit and the system is described in Section 5 – Testing and Adjustments.

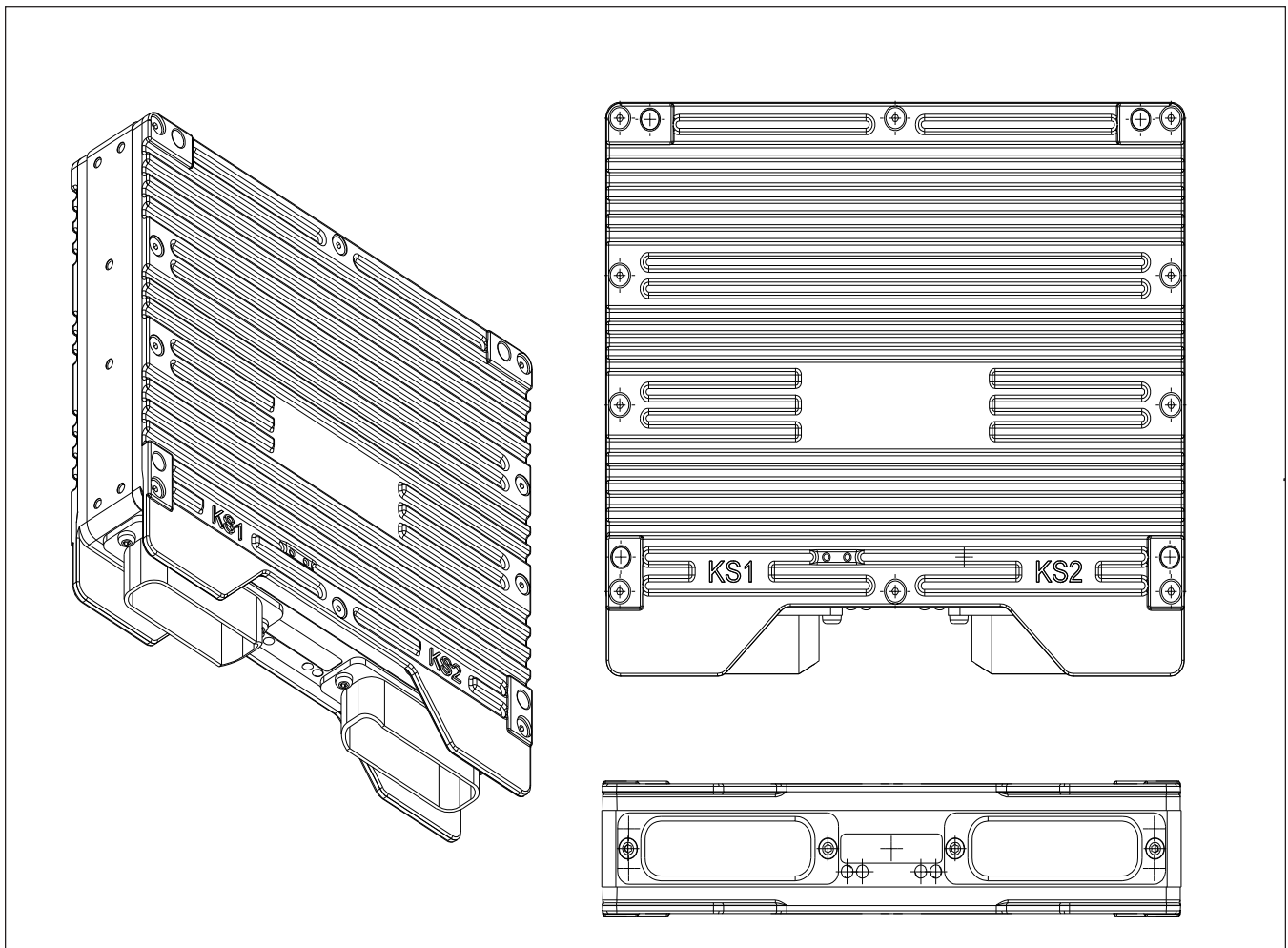

FIGURE 1 – TYPICAL CAB CONTROL UNIT



CAB CONTROL UNIT MOUNTING

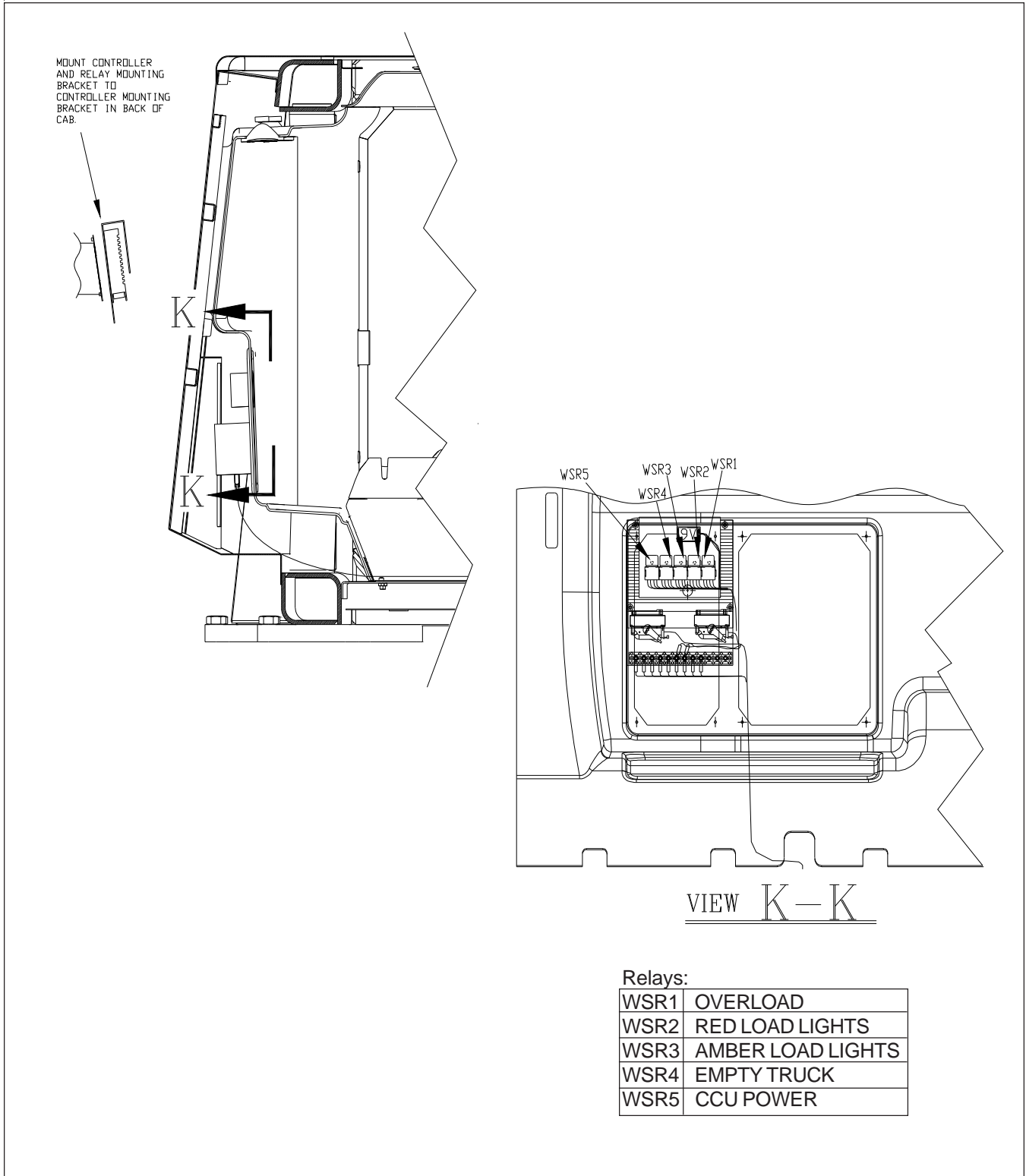

FIGURE 1 – TYPICAL CAB CONTROL UNIT MOUNTING



DESCRIPTION OF MICROPROCESSOR PROGRAM ON TRUCK

GENERAL

The purpose of the program on the truck is to collect data, display it on request, and transfer it to a laptop PC or dispatch system for analysis and review.

PRIMARY ROUTINES

The program is divided into 4 major routines as follows:

1. EMPTY

a. Active when truck is empty.

b. Continues until speed is 0 mph (km/hr) and the Load or Hand Brake is applied then the LOADING routine starts.

2. LOADING

a. Active when the truck is (or could be) being loaded.

b. It continues until the Load or Hand Brake is released.

c. After the Load or Hand Brake is released:

(1) If the payload increased by at least 25% of rated payload, the HAULING routine starts.

(2) If the payload did not increase, the EMPTY routine is restarted.

3. HAULING

a. Active when truck is loaded.

b. It continues until the dump body up switch has been on for 2 seconds, then the DUMPING routine starts.

4. DUMPING

a. Active when the truck is dumping a load.

b. It continues until the Load or Hand Brake is released and the dump body is down for 2 seconds.

The program continuously loops within one routine (every 0.1 second) until specific conditions exist that tell it to go to the next routine. The routine that was active when

the Master Switch (+24 Vdc power) was turned Off will be active when the Master Switch is turned back On.

OTHER ROUTINES

There are also subroutines that may be used at any time, such as;

1. UPLOADING: This is the transferring of data from the memory in the Weigh System to a laptop PC connected to the Weigh System through a serial connector located in the cab.

2. DISPLAYING DATA: Selected data is normally displayed in the cab. When one of the 4 push button switches on the Display is pressed, the program changes the display accordingly.

NOTES:

1. *There is an optional Large Display available on some trucks that adds the capability of displaying payload information on the left and right side of the truck. Each display has 3 LED characters approximately 10 inches (255 mm) high. The Large Display Panels are connected to the Weigh System Control Unit Serial Card and display the payload measurement selected by the operator.*

2. *The Large Display option is not available on some configurations of trucks due to space and other limitations.*

3. COMMUNICATING WITH LAPTOP PC: When data is detected on the serial input, the program responds by sending or receiving data as directed by the laptop PC.

4. COMMUNICATING WITH DISPATCH SYSTEM: When data is detected on the serial input, the program responds by sending or receiving data as directed by the dispatch system.

DATA

1. The date and time when the loading routine started is stored in memory.

2. The LOADING routine starts when the truck is at the shovel and the Load or Hand Brake is applied.

3. The payload is added/updated in the haul record each time a weight reading is taken during the hauling routine.

a. It is the difference between the weight recorded during the hauling routine and the empty reference weight.

b. The weight readings are only taken when several specific conditions exist for 3 seconds.

4. A less accurate weight reading is also recorded as the truck leaves the shovel and accelerates through a preset speed (i.e. 3 mph (5 km/hr)). This weight is used on the reports when the weight reading described above is missed.

5. The weight reading made under the shovel is also recorded after it is adjusted for possibly missing the last shovel full. This reading is compared with the weight taken during the haul routine to give an indication of how accurate the shovel weight was during a specific loading cycle.